

Tap Notch Grinding Fixture #0750.000-00

Designers & Manufacturers of Drilling & Tapping Solutions

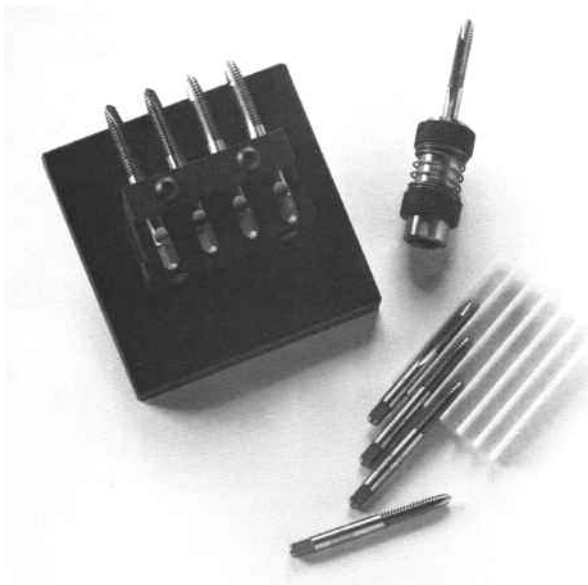

Cost-saving accessory for tap chucks

Convenient tap notch grinding fixture allows you to surface grind notch into tap shank.

Tap notch, which provides tap with radial float and allows it to self-align with the hole, is required when using taps in chucks and heads.

The fixture holds up to four taps and provides easy set-up and proper orientation on surface grinder. Unit is made of hardened tool steel and features spring-release clamp for quick, easy tap removal.

How to set-up and use notch grinding fixture.

1. Release adjustable Vee block locator
2. Place taps in the end Vees and orient square
3. Adjust Vee locator to tap square and clamp
4. Dress the surface grinding wheel to .093 radius
5. Clamp fixture to table and ensure that surface Z is parallel to the axis of the table
6. Locate surface Y and move over dimension A + .250 inches
7. Grind to depth B

Tap Shank Modification Dimensions

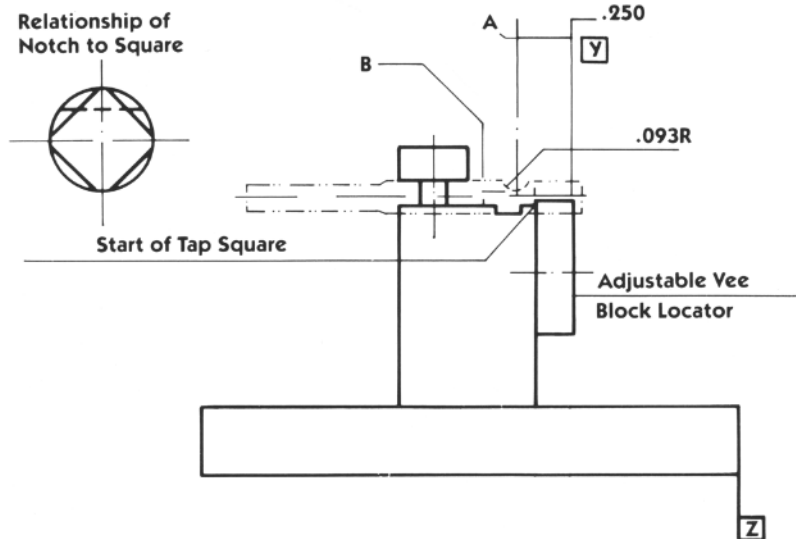

Holder or Collet Series	Dim. Tol. = ±.010	Hand Tap Sizes													
		0-6	8	10	12	1/4	5/16	3/8*	3/8	7/16	1/2	9/16	5/8	11/16	3/4
40.00-41.00	A	.219	.156	.156	.125	.125	.094	.094	.094	0	—	—	—	—	—
	B	.051	.054	.057	.060	.062	.074	.062	.070	.076	—	—	—	—	—
60.00-66.00	R	.093	.093	.093	.093	.093	.093	.093	.093	.093	—	—	—	—	—
44.03F	A	.188	.188	.188	.188	.188	—	—	—	—	—	—	—	—	—
	B	.050	.050	.050	.055	.055	—	—	—	—	—	—	—	—	—
54.03F	R	.093	.093	.093	.093	.093	—	—	—	—	—	—	—	—	—

